

# SMART TILT WALL & WINDOW SYSTEMS

MELBOURNE  
ADELAIDE  
BRISBANE  
SYDNEY  
PERTH

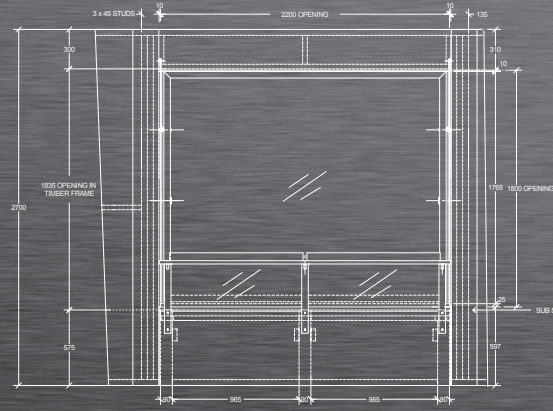

Internal Elevation - Smart-Tilt Window

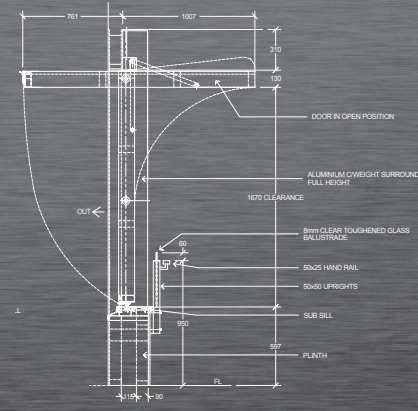

Section View - through opening at window



Available:

Head Office & Production Facility  
9 Production Road, Melton, Victoria 3337  
Phone (03) 9747 9233 Mobile 0403 321 840 Fax (03) 9747 9448  
Email sales@smarttechdoorsystems.com.au www.smarttechdoorsystems.com.au

# SMART TILT WALL & WINDOW SYSTEMS



*The smarter choice by design*



# SMART TILT WALL & WINDOW SYSTEMS

## Smart - Tilt Wall and Window Systems

The Smartech Door Systems' Smart-Tilt Wall and Smart-Tilt Window offer you the ultimate in indoor-outdoor living. Both the window and wall options operate on the same principle of literally lifting the window or wall up and above, leaving you with nothing but unobstructed views and a true sense of flow between your entertaining spaces. Our contemporary, design-driven products are known for their ease-of use and craftsmanship, so when you choose Smartech Door and Window Systems you can sit back and enjoy your new entertainment space confident in the knowledge that you've chosen the best possible product. Bring the outside in whatever the weather and create sophisticated spaces, all managed by the touch of a button.

### Features

- Range of glass designs
- Balanced opening system
- Range of powder coated colours available
- Aluminium frame and tracks
- Stainless steel components

### Smart Tilt - Window System

Height: 1200mm to 2000mm      Width: 1000mm to 4000mm

### Smart Tilt - Wall System

Height: 2200mm to 2700mm      Width: 1000mm to 4900mm

*Note: These sizes apply to the standard range. All widths are subject to variation depending on the choice of glass design and height required. Please consult manufacturer for a Window Specifications sheet along with the code number for ordering details.*

### Smart-Tilt Wall or Window System Opening

Smart-Tilt Wall and Window range fits within the door opening perfectly. Always refer to the opening measurements at consultation stage to marry your door or window opening space with door and window sizes, to guarantee a snug fit at seals, smooth operation and correct tolerances. Door and window openings are finished perfectly square, level and true. The base of the tilt window features a double rubber seal to close perfectly against sub sill extrusions. When designing your space prior to installation, please allow for the loss of height when door and window products are folded open as they rest at ceiling height. Refer to data sheet for detailed specifications.

### Smart - Tilt Wall or Window System Construction

The frame is manufactured as a single item with two axles attached, connected to running bearings which are guided within a specially extruded aluminium running guide.

*Note: Smartech's products are to be installed to the structure designed to suit our fixing requirements.*

### Window Frame and Fittings

The window frame is made of an extruded aluminium profile, creating the perfect sturdy and dependable base from which we build all our quality products. Additional running guides and fittings are all made from the highest quality materials with most components and fittings cast from stainless steel. With all Aluminium surfaces powder-coated as standard, you can be assured of the very best in quality.

### Locking

Both the Smart-Tilt Wall and Smart-Tilt Window System are fitted with side-bolt locks on each side of the lower window or door frame. No side bolts are supplied with the motorised option of either product to avoid jamming or safety concerns.

### Operation

Smart-Tilt Wall and Smart-Tilt Window Systems are balanced according to the weight of the window or door, allowing for a smooth and easy operation. Window and door movement is guided effortlessly by bearings attached to the frame, operating within our custom-designed extruded aluminium guides. The axles are located at the mid-point of the frame, allowing the products to pivot easily.

### Motorisation

Key switch and push-button controls are also available with most Smartech Door Systems products. As the motorised component is compact and hidden internally, clean lines are never compromised. The drive-spindle shaft is made from high-grade stainless steel and turns smoothly and effortlessly. Using the latest in available technology, the motor system senses the door or windows position during every moment of travel. All motorised doors and windows can be operated by the touch of a button, or additional key switch.

### Awning Windows

Awning windows are an added option for your Smart-Tilt Window System for the days when weather does not permit the product to be completely open, but when you still want to enjoy air flow within your property. The awning window option is available in sizes up to 600 H X 800 W. Please consult the manufacturer for more information.

### Key Benefits

Both the Smart-Tilt Door and Smart-Tilt Window Systems open up and rest parallel with the ceiling avoiding stacked panels to the side of the opening, as is the case with our competitors' designs. The result is a user-friendly and aesthetically pleasing look, with no running track and the style and quality our customers have come to expect. Our quality construction and design standards ensure you will purchase a product that is hard-wearing and always stylish.

### Glass

All glass supplied by Smartech Door Systems is 6.38mm laminate safety glass as standard. Electric 'Switchable Glass' is also available; just mention your interest at consultation. If other glass alternatives are needed, please consult the manufacturer.

*Note: The use of other glass or glazing material should be referred to the manufacturer due to additional weight that may or may not be required to keep the window system operating easily.*

### Smart Tilt System Operational Diagrams

Smart - Tilt Window System



Smart - Tilt Door System Operational Diagram



### Standard Glazing Designs

Smart - Tilt Window System Single Pane - T - Window

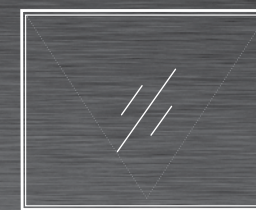

Single Pane - T - Wall



Double Pane - T - Wall

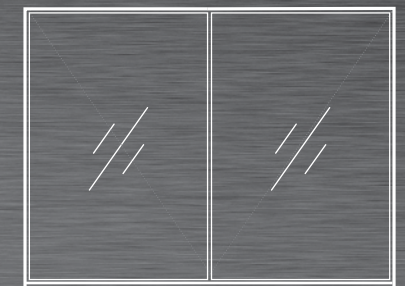
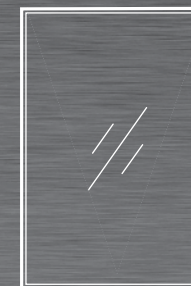

Designed for modern contemporary apartments and houses.



Natural environments to flow through inside or out, great for beach houses with coastal views.



Internal Balustrade system to enjoy the balcony, being in the living room.



Large viewing Single Pane Tilt-Wall windows



The smarter choice of an internal balcony system

